



REF TEK

Unshakable.

Miniature Seismic Recorder MODEL 125A-01

Applications:

Active Source Crustal Studies Refraction
Active Source Crustal Studies Reflection
Exploration 3-D Noise Testing and
Tomographic Arrays
Aftershock Studies
Micro-Zonation Survey

Features:

Low Power 24-bit ADC: powered from
two "D" cell batteries
Small, Lightweight, and Sealed
Aluminum Case
Solid-state Data Storage
Time Base Stability 0.1 ppm:
GPS synchronization
Industry Standard Hi-Speed (480Mbit)
USB2.0 Interface



Introduction

The 125A Miniature Seismic Recorder (Texan) is an important advancement in the seismology industry. The Texan's self-contained, compact design allows greater flexibility and the ability to easily integrate into system operations.

In crustal scale refraction experiments, hundreds of instruments are deployed over several hundred kilometers for two to four days duration. Recordings are made based on pre-set time windows at a rate of 100 samples per second (sps). Because explosions are typically being recorded, a maximum of 50 time windows of 120-second duration will also be recorded. The Texan's data storage requirement for this application is about 2 MB. Timing accuracy for the four day period must be within ± 5 msec relative to the shot time.

For crustal scale reflection experiments, instruments are deployed for three to five days with six to eight hour continuous recordings using a vibrator energy source. After each day's recording, data is downloaded, and the Texan is initialized for the next day's recording. Because the data may be stacked, time accuracy must be within ± 2 msec. Time accuracy must be within ± 2 msec since the data may be stacked.



Water geyser from under water explosion during CTBT tests in Wyoming, summer 1997.

How The Name “Texan” Came About

The Miniature Seismic Recorder is a joint project between the Texas Universities Seismic Instrumentation Alliance¹ with funds from the State of Texas Advanced Technology Program thus the name “Texan.” In addition, support is provided by IRIS/PASSCAL² and several Texas-based energy companies.

¹ The Texas Universities Seismic Instrumentation Alliance includes the University of Texas at El Paso, Rice University, and the University of Texas at Dallas.

² Program for the Array Seismic Studies of the Continental Lithosphere under the Incorporated Research Institutions for Seismology, an international consortium with 100 member institutions.



Demonstrating the installation of a 125A station.

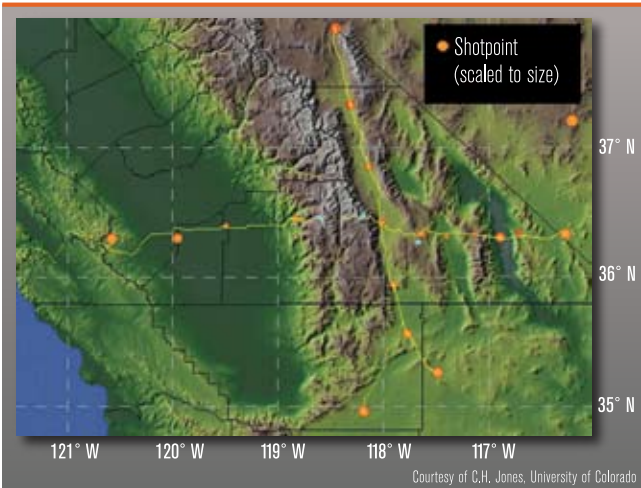

This topographic map shows a typical active crustal studies experiment plan.



Drilling shot holes during Polonaise experiment, May 1997.

The self-contained Texan features a low-noise differential input amplifier, 24-bit analog-to-digital converter (ADC), solid-state data storage, and batteries, all in a sealed aluminum case. Up to 15 Texans are stored, setup, and transported. For setup, the Texans are connected to a hub that provides power, connection to the host computer via Hi-Speed USB2.0, and timekeeping signals from a GPS receiver.

The hub provides several important functions:

1. The hub provides for 15 Texan connections, a connection to the USB host, and one port for daisy-chaining additional hubs. Several hubs can be operated in parallel allowing simultaneous connection between a single host computer and numerous Texans.
2. Routes the 130-GPS Receiver/Clock signals to each Texan for synchronizing internal time to UTC and precisely setting the internal oscillator frequency.
3. Supplies power to the Texans for setup and data retrieval.

After setup, the Texans are deployed for recording. A state LED displays the operating condition of the Texan. This feature clearly informs the user that the battery voltage is sufficient, time is set, the acquisition program loaded, and the unit is either ready to acquire or is acquiring data. During the recording session, the Texan can be retimed or data may be downloaded to a laptop PC. At the conclusion of the experiment, the Texans are returned to the setup facility, retimed, and the data downloaded to the workstation for processing.

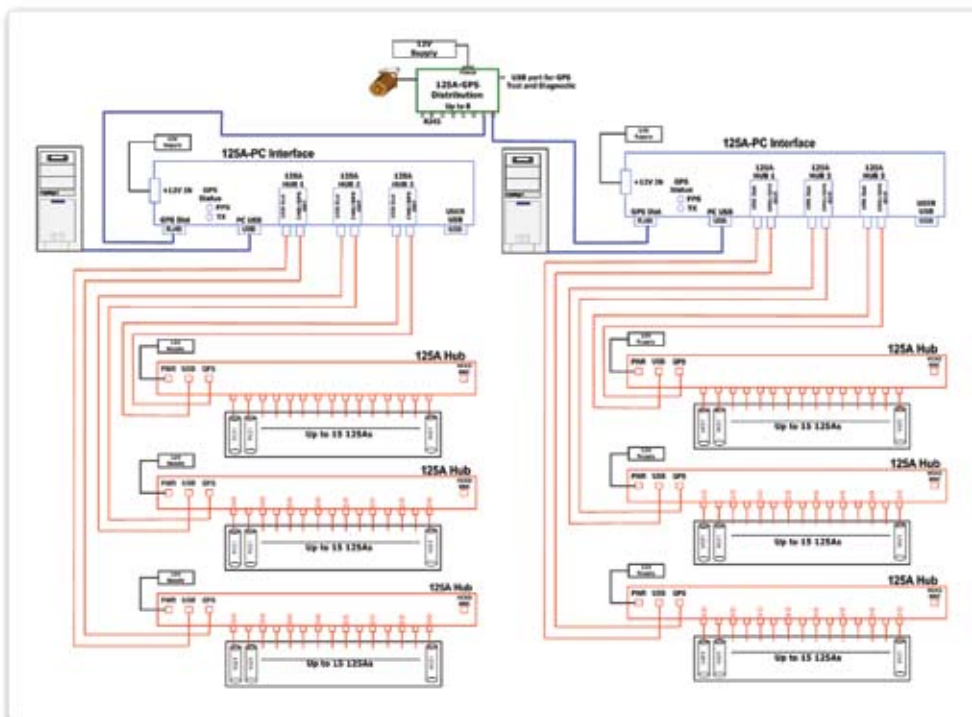

REF TEK

Refraction Technology, Inc.
1600 10th Street, Suite A
Plano, Texas, 75074 USA
(214) 440.1265 phone
(972) 578.0045 fax
www.reftek.com
info@reftek.com

Related Sub-systems:

Third Generation Broadband Seismic Recorders, 130-01 & 130B-01
Strong Motion Accelerographs, 130-SM & 130-SMA
Accelerometers, 131A & 131B
Advanced Seismic Networks

Specifications subject to change without notice. Rev. 3.4
©2007 Refraction Technology, Inc. Printed in the U.S.A.

125A-01 Specifications

Physical

Size: 3.0" (76mm) diameter x 7.7" (196mm) length
Weight: Less than 2.5 lbs (1.1 kg) including 2 "D" cell alkaline batteries.
Operating Temperature: -40°C to 60°C
Watertight Integrity: Water immersion without leaking in 2 meters water (48 hours), air tight to 2.5 psi.
Shock: Survives 1m drop on any axis

Power

Internal Batteries: "D" cell alkaline, two required
Voltage: 1.6 VDC - 3.0 VDC
Current: 50 micro-amp - sleep
25 mA - standby
125 mA operating
External
Voltage: 5 - 15 VDC
Current: 50 mA @ 5V; 200 mA @ 5 V Hi-Speed USB access

A/D Converter

Input Impedance: 2 Mohms, 0.2 uFd, differential
Common Mode Rejection: Greater than 70 dB
Gain Selection: Variable Gain x4 - x256 (by factor of 2)
Full Scale Input: 5 Vpp - 78,125 mV (by factor of 2)
Type: Δ - Σ modulation, 256 KHz base rate
Sample Rate: 1000, 500, 250, 200, 125, 100, 50, 25 sps

Data Storage

Word Size: 24-bit two's-complement (3 bytes per sample)
Storage Type: Hi-Speed USB Flash drive
Capacity: 128, 256, 512 MB

Trigger For Crustal Studies:

Description: Recording windows are programmed by the host PC as start and stop time.
Time Trigger: 1000 trigger times may be programmed
Record Length: A minimum of 1 second to maximum time that will fill the data storage.

Time Base

Frequency: 2.048 MHz, electronic control
Stability: ± 0.1 ppm from 0 to 50° C; ± 0.3 ppm from -20 to 0° C

Host Interface

Type: USB2.0 for command / control, data upload, firmware download

Connectors

Seismometer: U229/U
Power/I/O: U77/U

