

National Geophysical Networks in Latin America Best Practices, Challenges, and Opportunities for Collaboration

Universidad de Chile Santiago, Chile May 25-30, 2015

Venezuelan Geophysical Networks Seismic and GPS

Herbert Rendón, Miguel Palma, Carlos Reinoza, Ricardo López

Tectonic Setting



Venezuela Seismicity Map

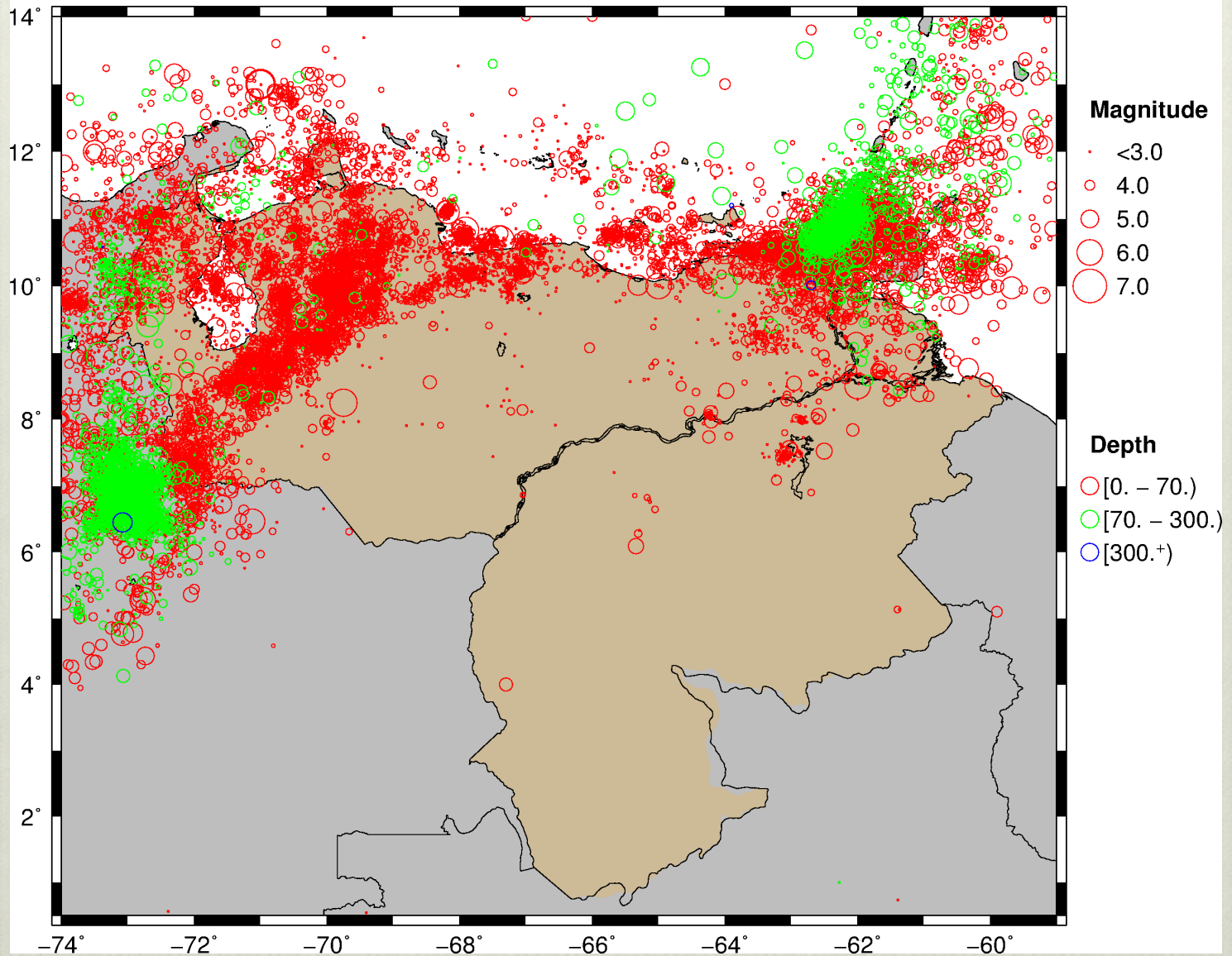

Outline:

1. Seismic Network
2. Strong Ground Motion Network
3. GPS Network
4. Temporal Networks

1. Seismic Network

Venezuelan Seismic Network

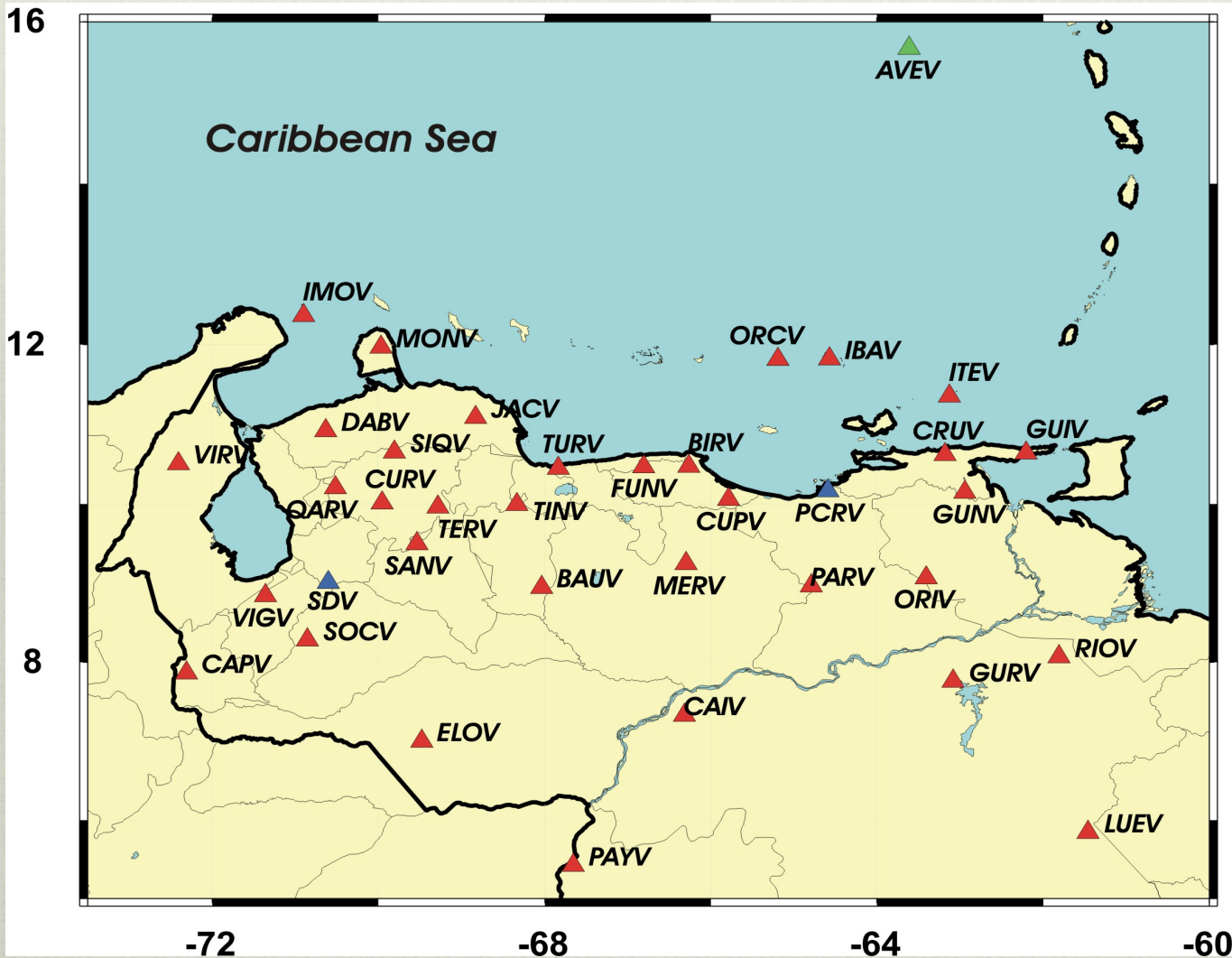

35 BB Seismic Stations equipped with Guralp sensor and digitizer (CMG-40T)

2 VBB Seismic Stations within the CTBTO Global Network, they are **AS117** (IRIS station with Streickessen sensor) and **AS118** (35 m Borehole station with GURALP sensor).

Geological and Geophysical assessment prior to site selection

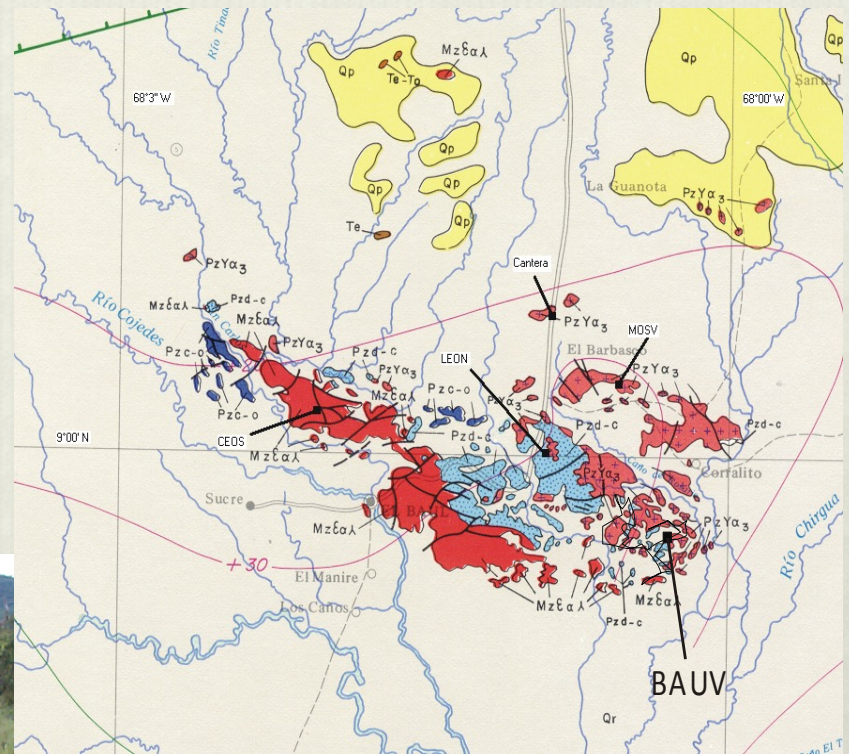

EL BAUV site in western Venezuela

Evaluation for the site El BAUL

Waveform Profile

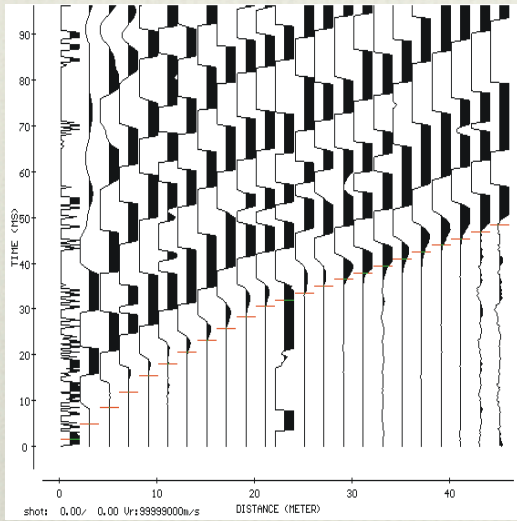

Evaluation for the site El BAUL

Waveform Profile

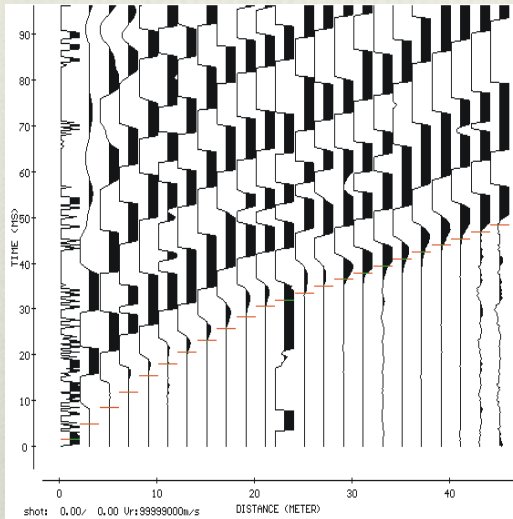

Travel Time/Ray Tracing

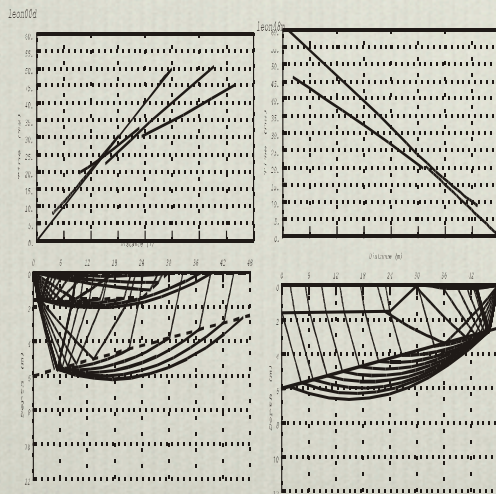

Evaluation for the site El BAUL

Waveform Profile

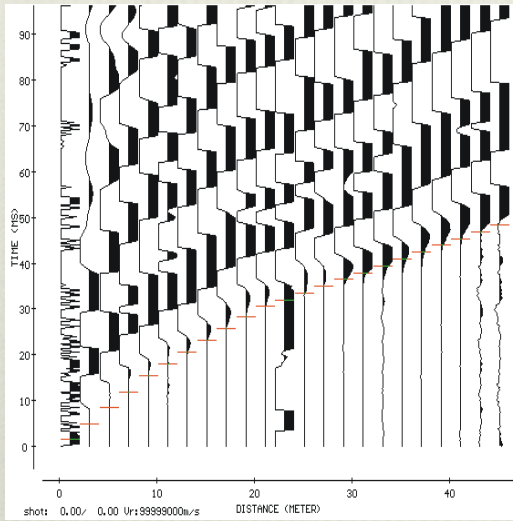

Velocity Model

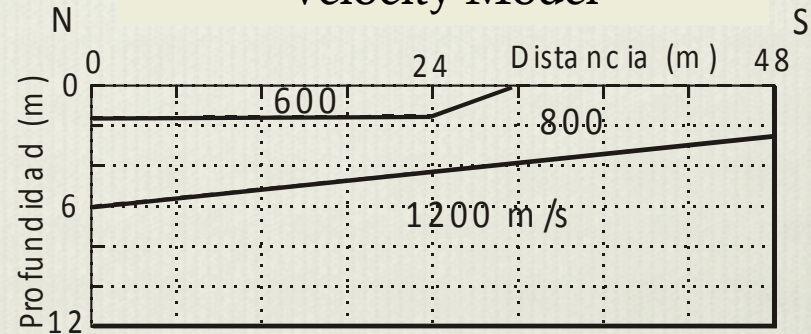

Travel Time/Ray Tracing

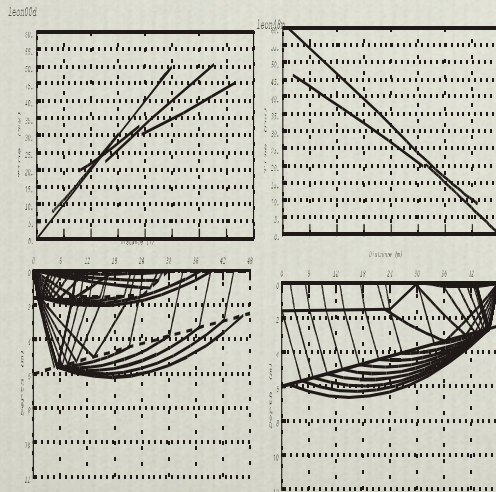

Evaluation for the site El BAUL

Waveform Profile

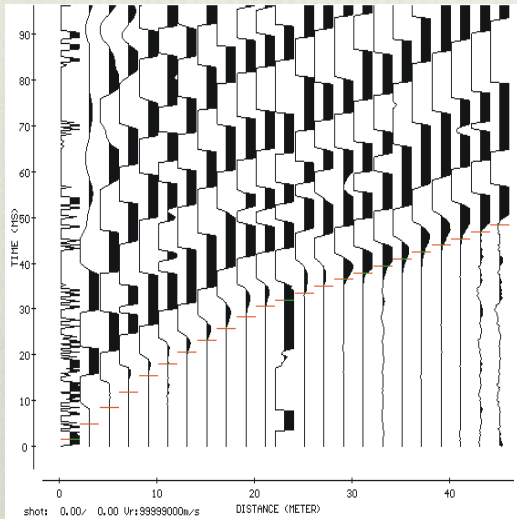

Velocity Model

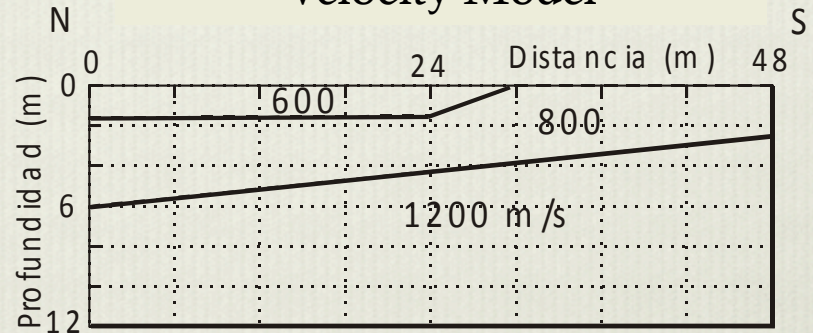

Seismic Noise Measurement

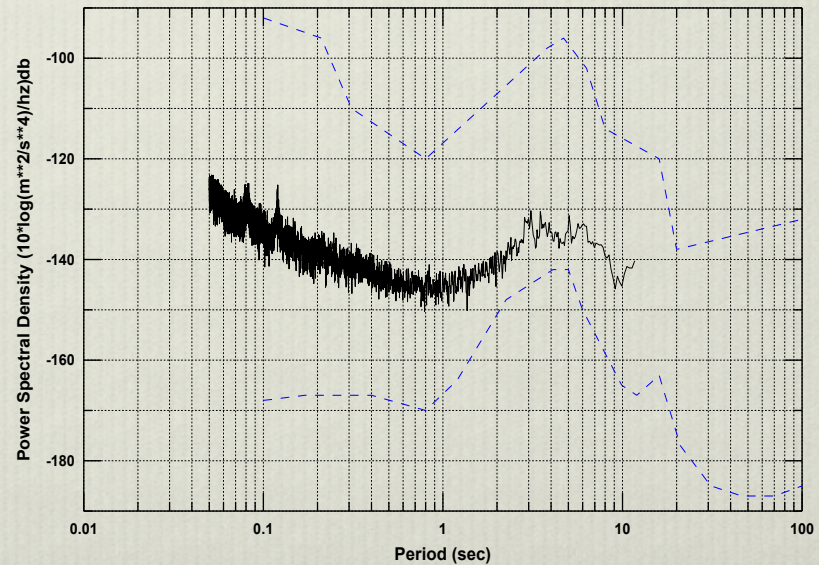

Travel Time/Ray Tracing

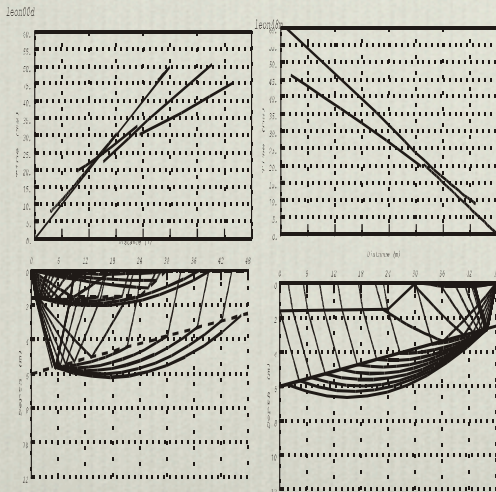



- Vault with reinforced concrete.
- Concrete basement 1m deep to enhance the coupling of the sensor to the ground.



- Vault with reinforced concrete.
- Concrete basement 1m deep to enhance the coupling of the sensor to the ground.

- Broad-band sensor Guralp CMG-40T
- Flat velocity response in the range (0.03 – 50.) hz.



Some Stations



TEREPAIMA, EDO. LARA

Some Stations



LOS MONJES

*National Geophysical Networks in Latin America
Santiago-CHILE, May 25-30, 2015*

Some Stations



JACURA, EDO. FALCÓN

*National Geophysical Networks in Latin America
Santiago-CHILE, May 25-30, 2015*

Some Stations



SEP 30 2003

GUANOCO, EDO. SUCRE

*National Geophysical Networks in Latin America
Santiago-CHILE, May 25-30, 2015*

Some Stations



SEP 30 2003

BIRONGO, EDO. MIRANDA

SEP 17 2003

In the 2012, an upgrade to the equipment and software that is operated by the National Seismological Service, FUNVISIS aimed to improve on the robustness and security of the acquisition system, analysis and backup

Automatic Earthquake Location:

Automatic seismic location, local and regional, are achieved by the use of different modules given by the EARTHWORM system. Preliminary results are given in less than 5 minutes after the event has occurred. Information is posted in the webpage and it is given with a note caution.

Interactive Earthquake Location:

With the system EARLYBIRD an interactive preliminary quickly solution could be provided with the on-time intervention of the in-house analyst.



Manual Earthquake Location:

Using SEISAN, the final result for the event location is obtained by the analyst after a careful revision. Later, this result is compiled and distributed under the figure of a **Reporte-Sismológico**. The issue of this report could take 10 to 15 days after the occurrence.

ACTUAL CONFIGURACIÓN DEL SISTEMA DE ADQUISICIÓN

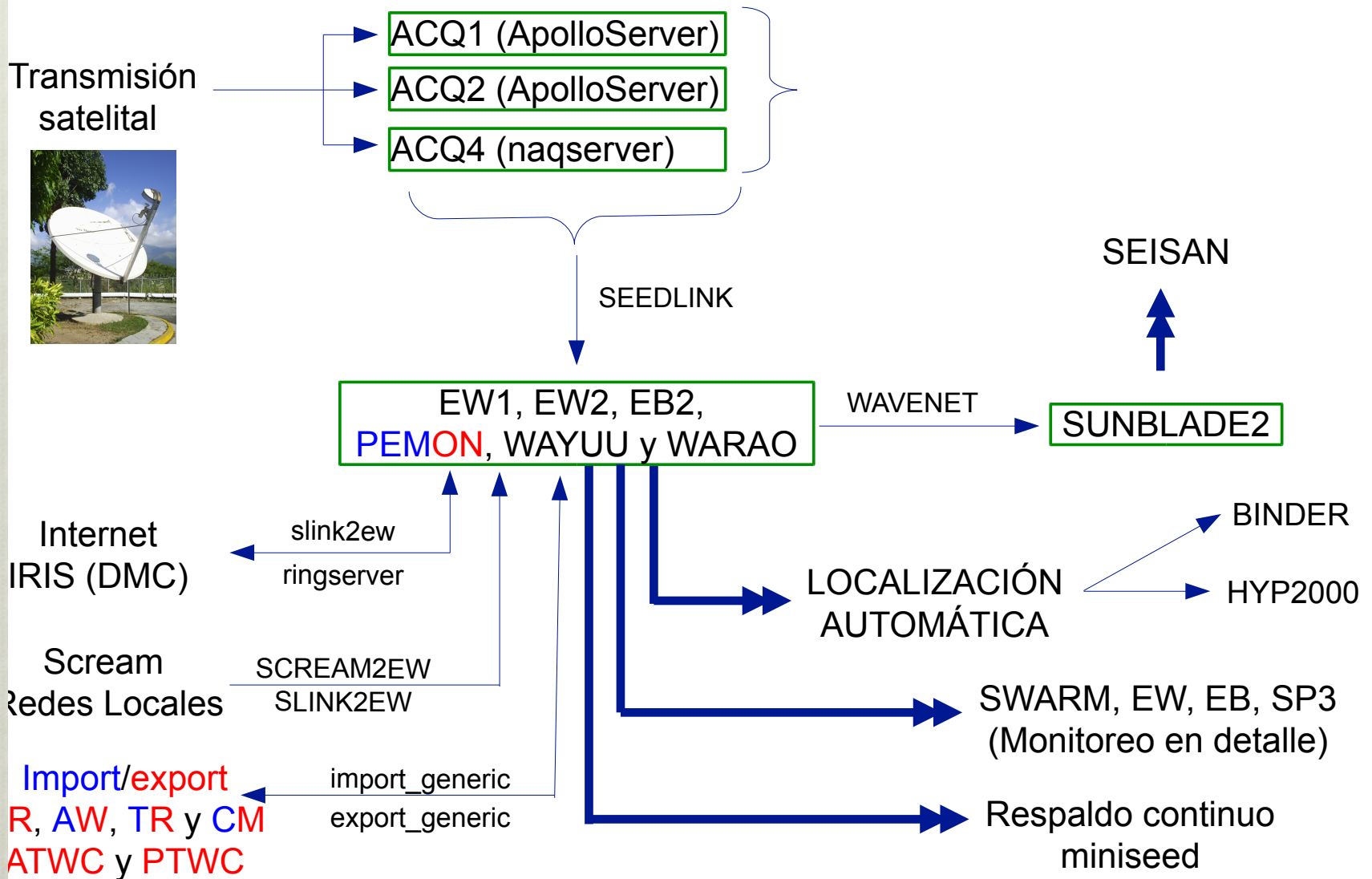

The HYPOCENTER algorithm within the SEISAN package is used to produce seismic event location.

The Seismic Database is maintained within the structure that SEISAN offers for waveforms the calculated events (S-files) and the Seismic Catalog.

Data request from the Database is done with the tools that SEISAN offers.

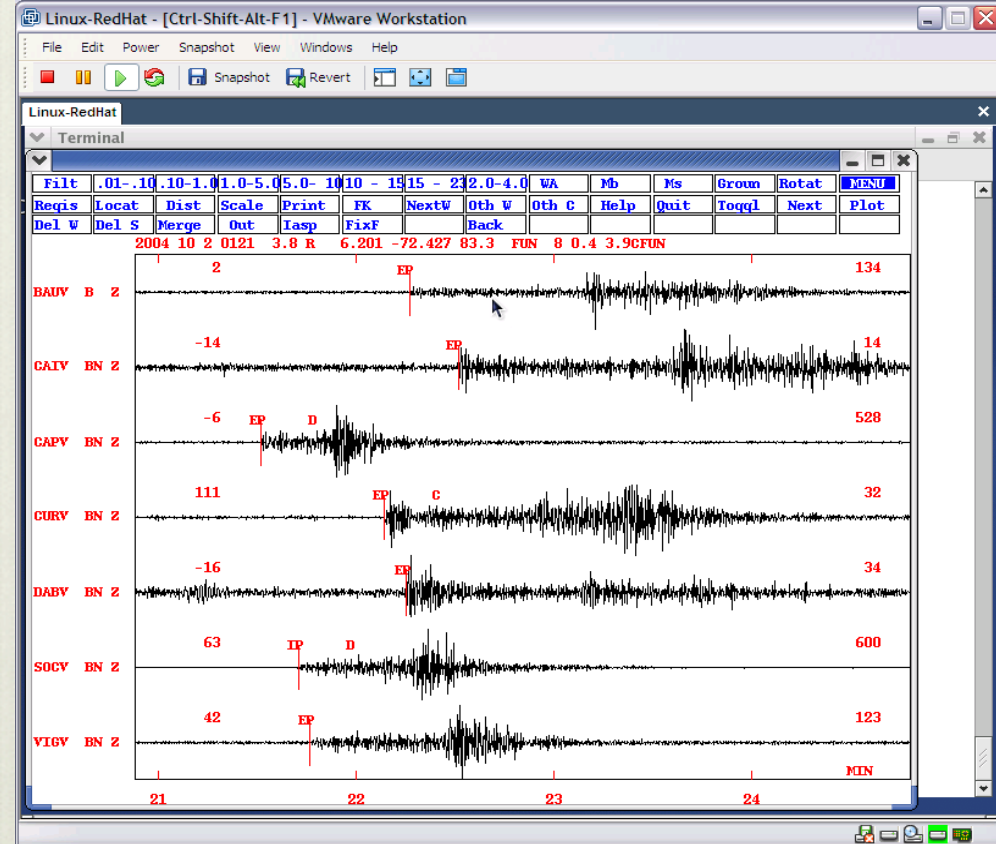

The HYPOCENTER algorithm within the SEISAN package is used to produce seismic event location.

The Seismic Database is maintained within the structure that SEISAN offers for waveforms the calculated events (S-files) and the Seismic Catalog.

Data request from the Database is done with the tools that SEISAN offers.

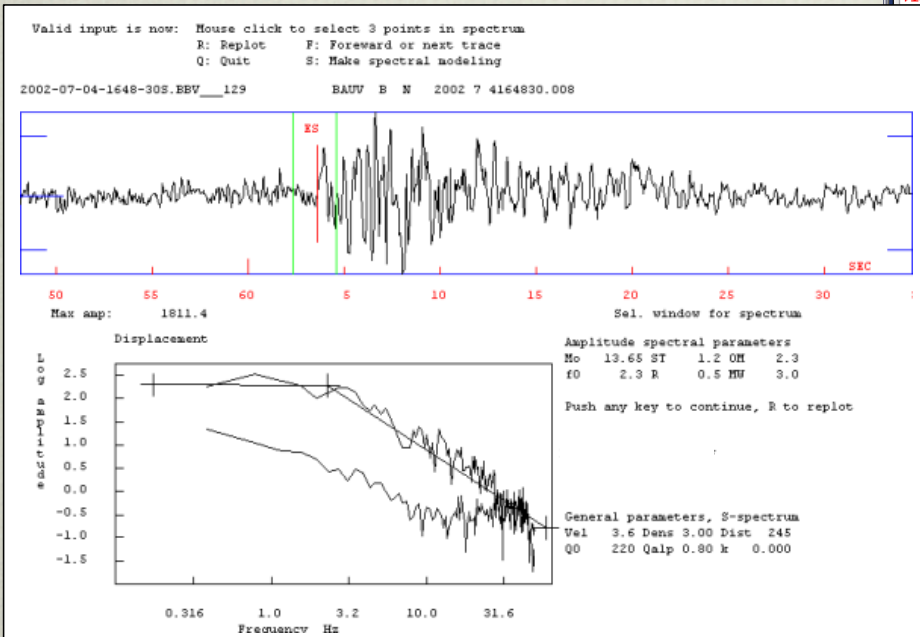
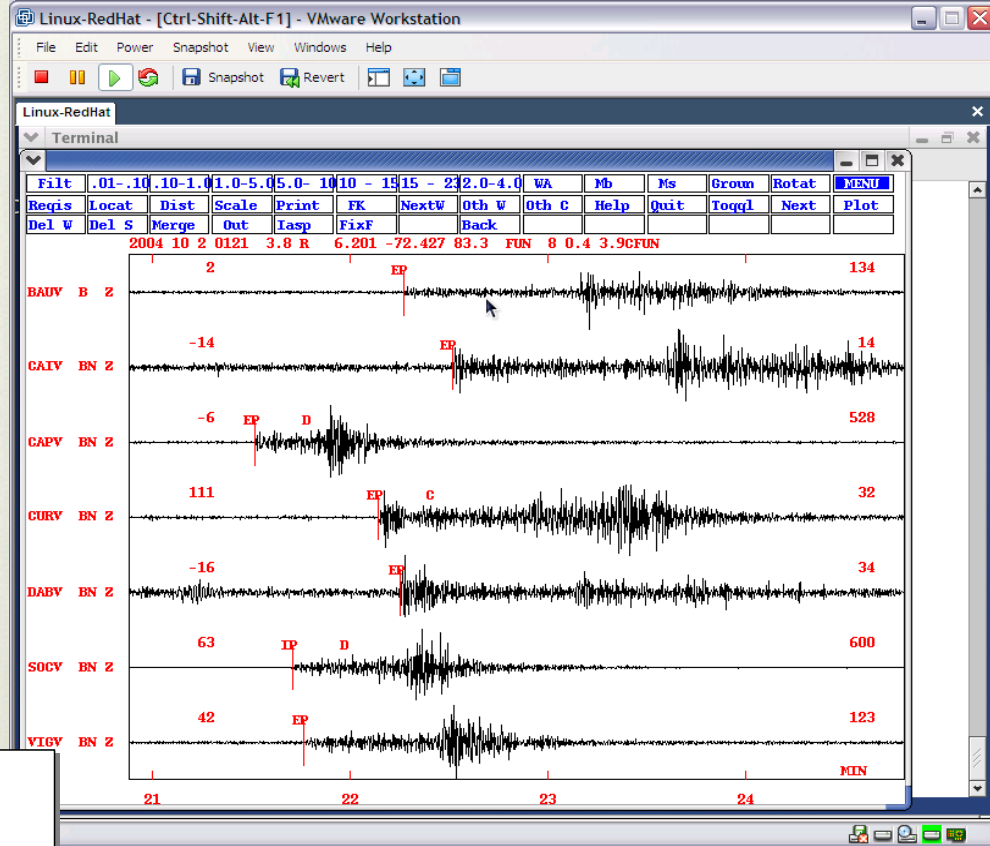

In a routine basis, magnitude is computed using M_w , and focal mechanism are determined for the bigger events using polarity of the first arrival.

Implementing the routine to compute Moment Tensor components

Short Period Seismic Stations

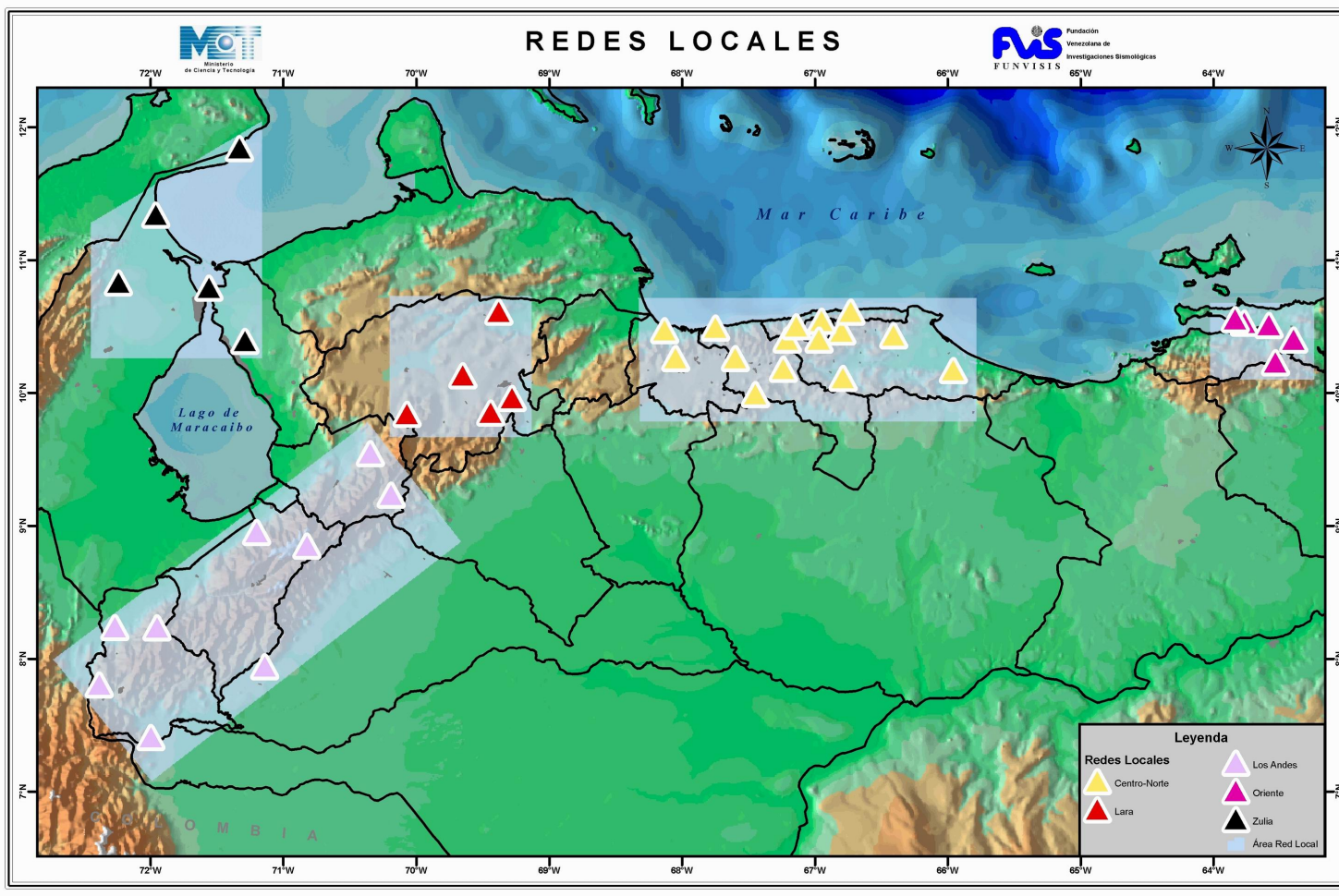

40 short period seismic stations grouped en **5** local networks. Stations are equipped with the CMG-40T1.

CONNETC TO
FUNVISIS VIA
TELEPHONE
COMPANY



Data Adquisition
Server

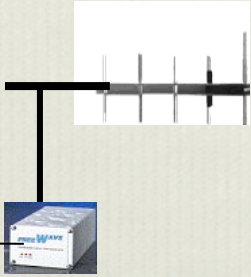

Radio FreeWave
921-928Mhz

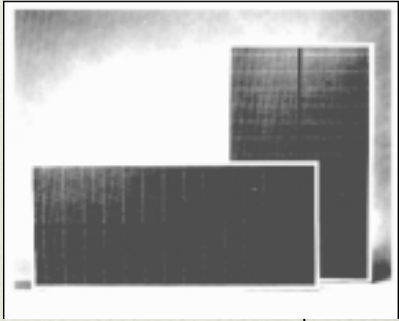
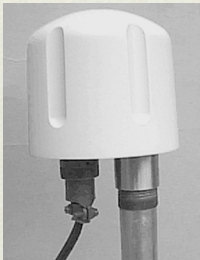

Voltage
Regulator



Digitizer
DM-24



Battery

Sismómetro
Guralp CMG-40T1



2. Strong Ground Motion Network

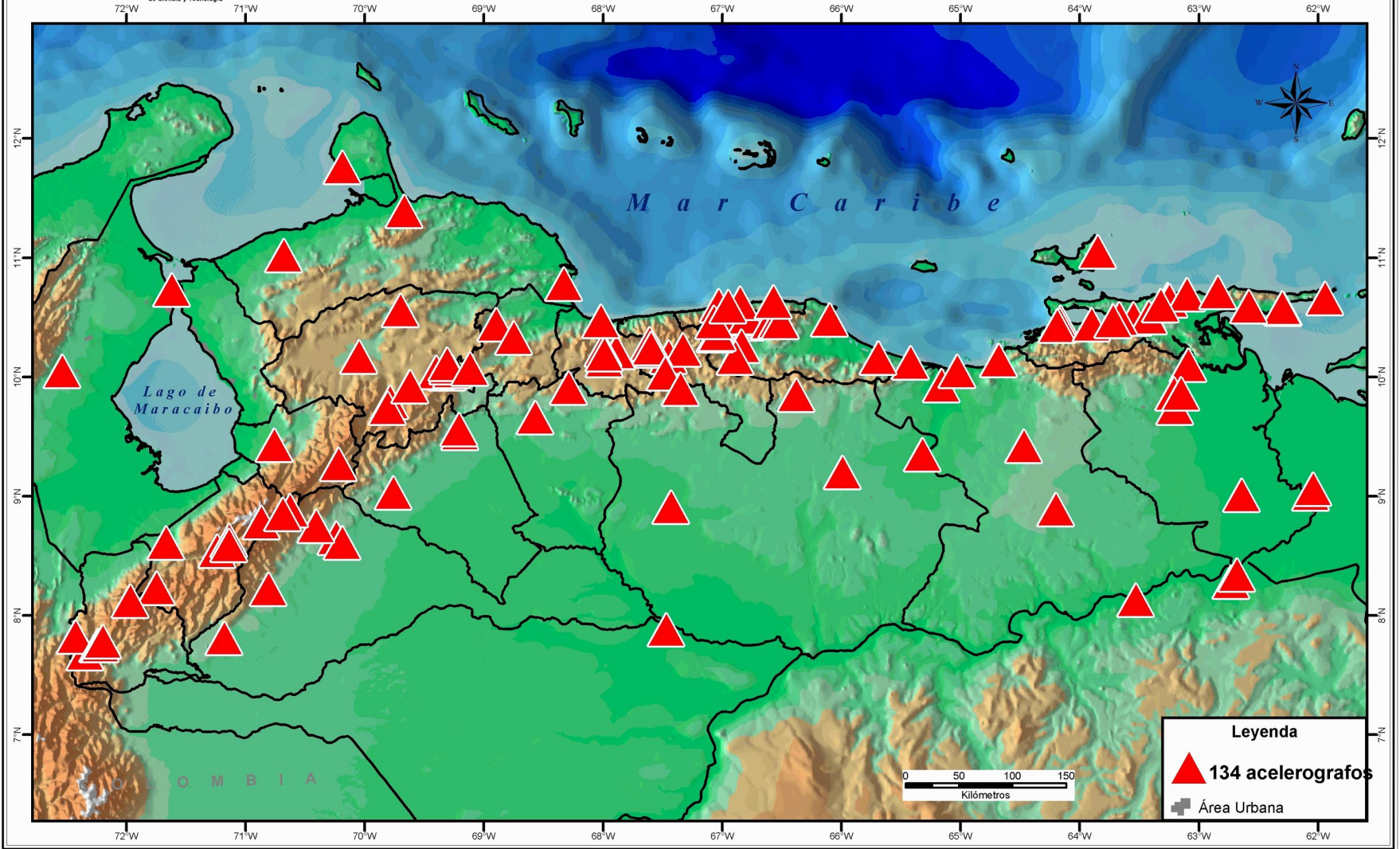



134 Strong Ground Sites with Etna equipment from Kinemetrics



3. GPS Network

- From 2003 to 2015, GNSS observations carried out by FUNVISIS-COCONET achieved a number of GPS campaigns.
- More recently, and in collaboration with UNAVCO, plans are underway to install five (5) permanent cGNSS stations, two (2) in mainland and three (3) in Leeward Antilles islands, the first two (2) are already recently installed:
 - 1) Quebrada Arriba in Lara and
 - 2) Baúl in Cojedes.
- Currently, FUNVISIS, through TWO nationally funded projects, will install seven (7) + (11) permanent cGNSS stations nationwide; and procure four (4) campaign receptors. For the time being, there is not a definite selection of the sites of the stations; however, the place of the national seismic stations represent potential locations under consideration, this guarantees satellite communication and security of the equipment.
- For the near future, we have plans to install a Creep-meter and two additional cGNSS to both sides of the Pilar Fault to work on detecting the potential variation in time and space of the creep process (creep pulses?) already manifested along the El Pilar Fault. This activity will be conducted with the collaboration of University of Savoie Mont Blanc- ISTerre, France.

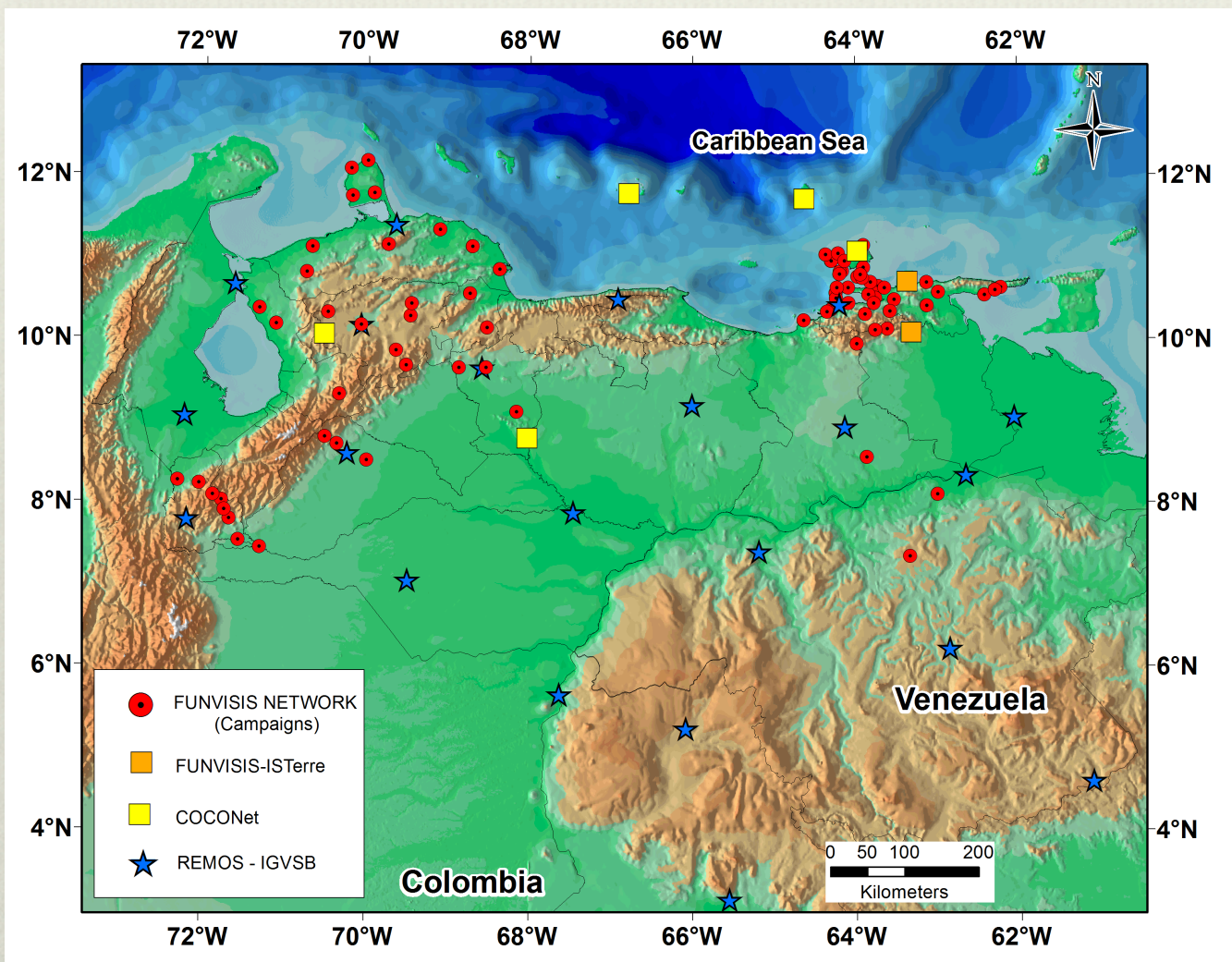

4. Temporal Networks

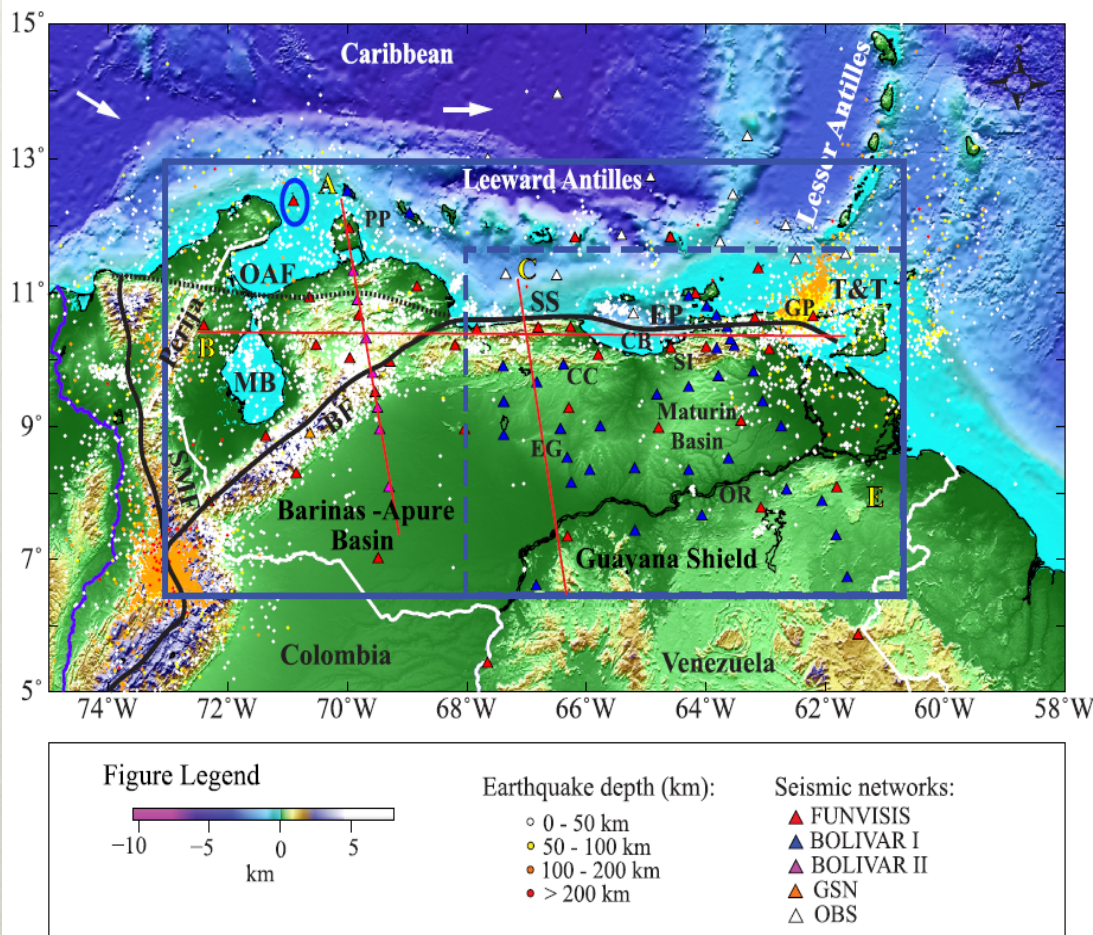

BOLIVAR PROJECT

Join effort between FUNVISIS, with the permanent national seismic network, and the temporary deployed BB seismic array, which includes OBS, funded by the NSF with the participation of Indiana and Rice Universities in Venezuela.

OBS and stations in Eastern Venezuela operated from 2003 to 2005.

The stations along the N-S profile in western Venezuela that were operated during the period 2008 to 2009.

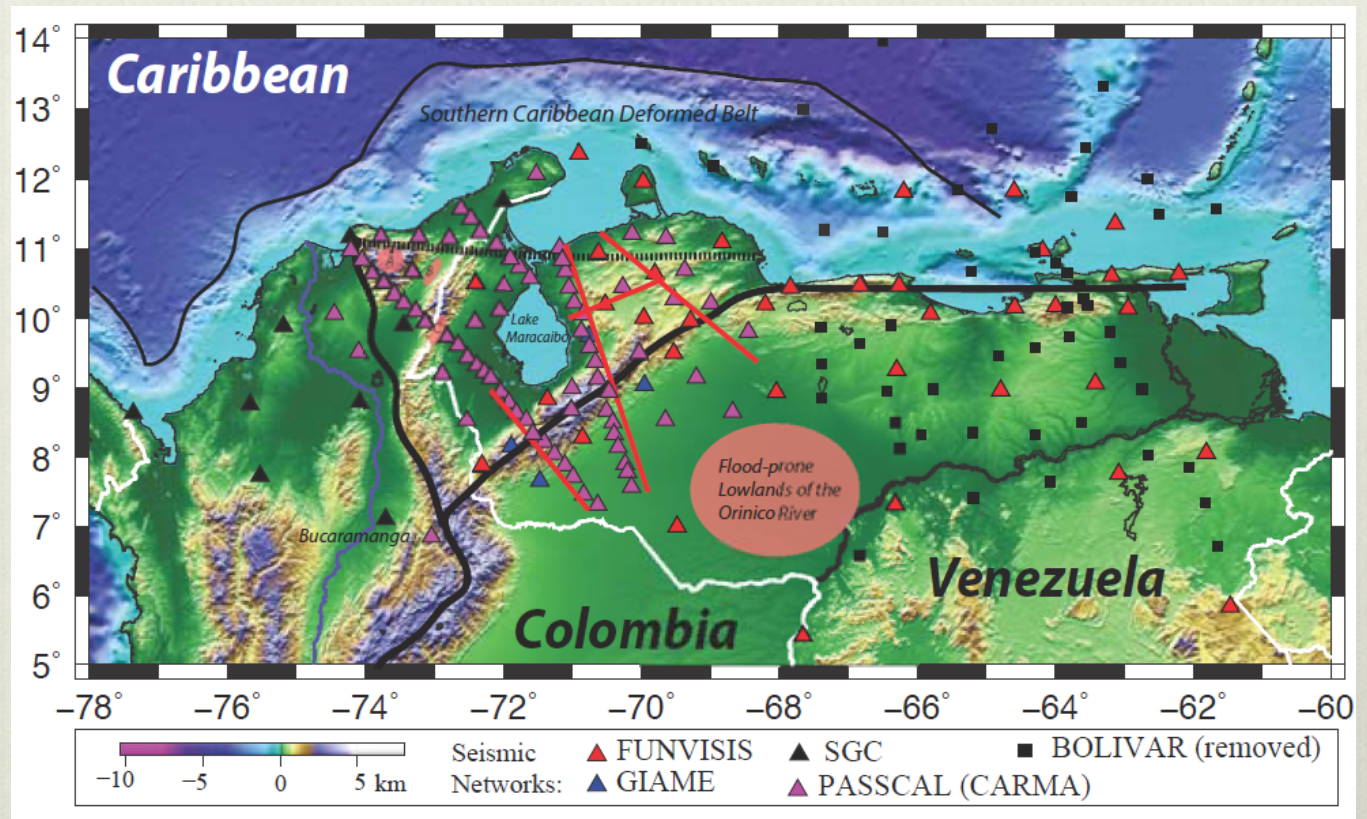

MAPS PROJECT

Seismic Observation that will be in place with MAPS (Merida Andes, Perija, Santa Marta) Project. A set of new sites foreseen for 2016 and 2017 with the deployment of BB equipment, as a complement to the permanent Venezuelan and Colombian national networks, and 2 dense refraction lines in western Venezuela (Rice University, FUNVISIS, Colombian Geological Survey).

Muchas Gracias