



**SILICON**  
AUDIO

# Optical Seismometers

Brad Avenson

[brad@siaudio.com](mailto:brad@siaudio.com)

# Geophone + Interferometer

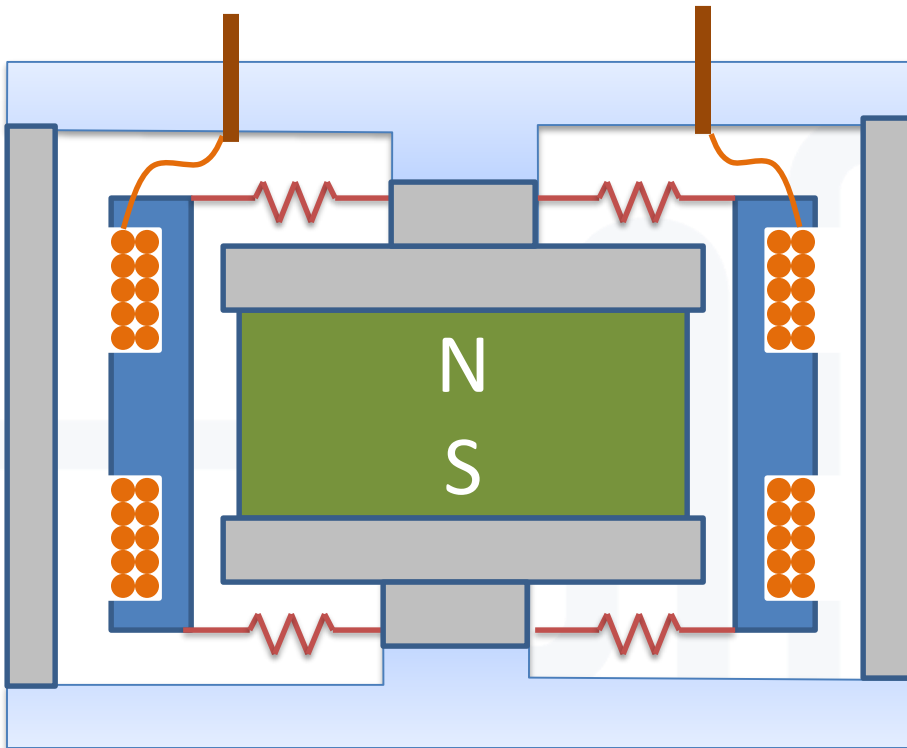

+

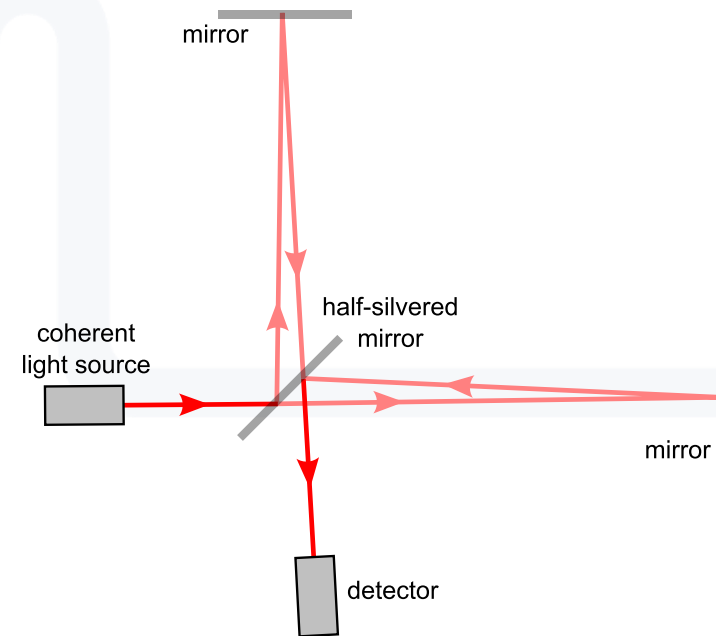

# Optical Accelerometer

Optoelectronics



Optoelectronics

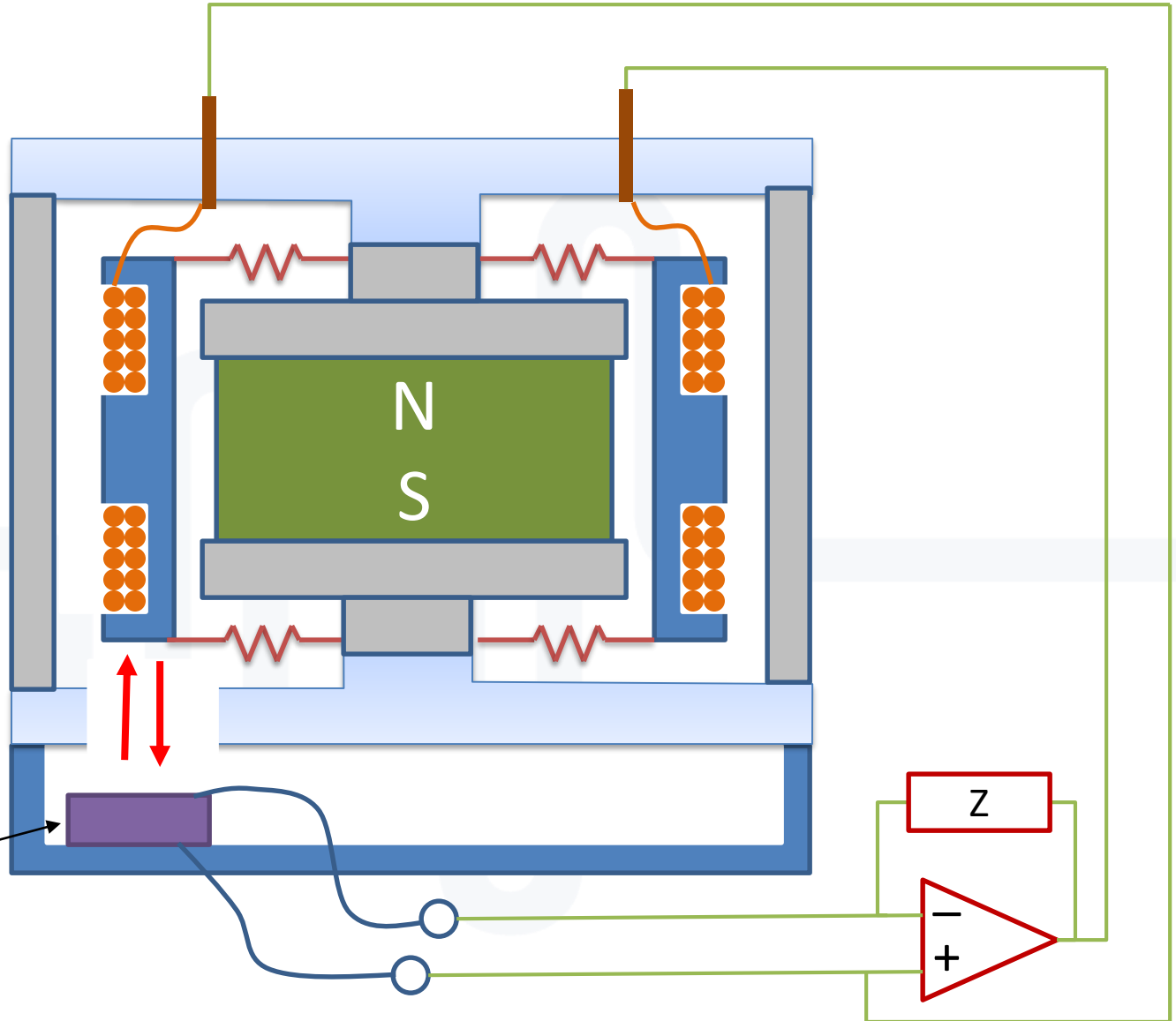



# Advantages

< 140 mW  
As low as 80 mW

Low power

High  
Dynamic  
Range

Up to 183 dB

Large Tilt  
Tolerance

Small Size

0.002-800 Hz

Wide  
Bandwidth

Robust

Tested to 3000g  
shock

# Model Variations

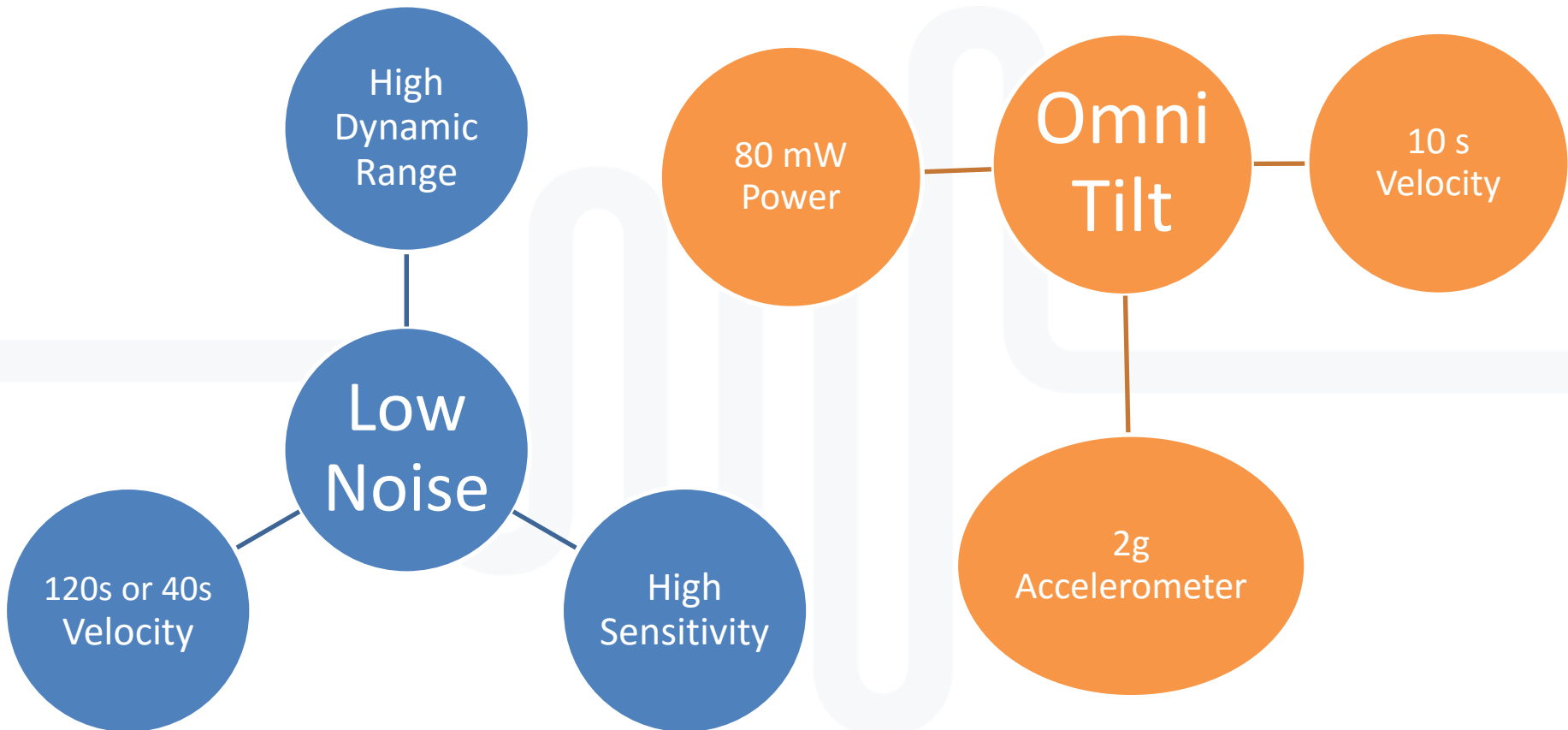



# Packaging Variations

Single Axis



Vault Style



Posthole



3C pod



# Dynamic Window of Operation

